



KONICA MINOLTA

# DiALTA™

Di 2510 f / Di 2510



**25**  *copies/min*  
A4 Crosswise

The essentials of imaging

# Core Information Machines That Take Document Creation to A Higher Level

The concept of office productivity is being elevated to a new stage. Systematising latent information to restructure knowledge creates a new value. And with the Di2510f/Di2510 digital multifunctional peripheral you now have the power to match the next-generation office by transforming documentation to a new and higher form of communication.

## Linked / Interactive Communication\*1

- Ultra fast e-mail-based information transmission provides a level of communication that surpasses time and place.
- Network scanning lets you quickly store or distribute paper-based documents as digital data. It consolidates the management of paper and data information, which could only be used separately in the past, and promotes more versatile forms of use for both.
- Information can be exchanged with a variety of equipment via Internet, Intranet, or phone line\*2. This smart communication capability lets you select the best communication means according to your needs.

\*1 Requires an optional Printer Controller, Network Interface Card and Scan Unit.  
\*2 The Di2510f exclusively.

## Innovative Creations

- Original Konica Minolta document management software makes scanned documents easier to see and use, thus raising their application possibilities to new heights.
- Innovative output operation maximises advanced network functions, which precisely meet office needs and expand the scope of document usage.

## Easy / Comfortable Operation

- A host of easy-to-use functions enable anyone to operate the machines. Plus, these advances have been integrated into the product's engineering, resulting in a truly universal design.

Linking to the Di2510f/Di2510 results in an integrated control system for the paper documents and PC files, which previously had to have been managed separately. In addition to making it possible to share information assets throughout the office, this system now creates a workflow that processes and outputs data according to specific needs, thus allowing a speedier, more effective use of information.

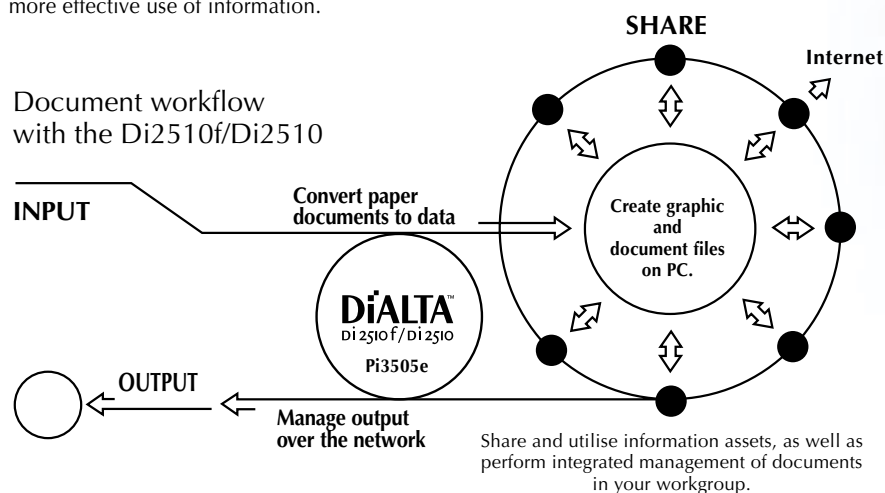

DiALTA<sup>™</sup>  
Di 2510 f / Di 2510



## A variety of information flows.

This machine's smart communication capability solves such problems as the communication environment, as well as costs and usage form, all commonly associated with the exchange of information in the office.

(Requires an optional Printer Controller, Network Interface Card and Scan Unit.)

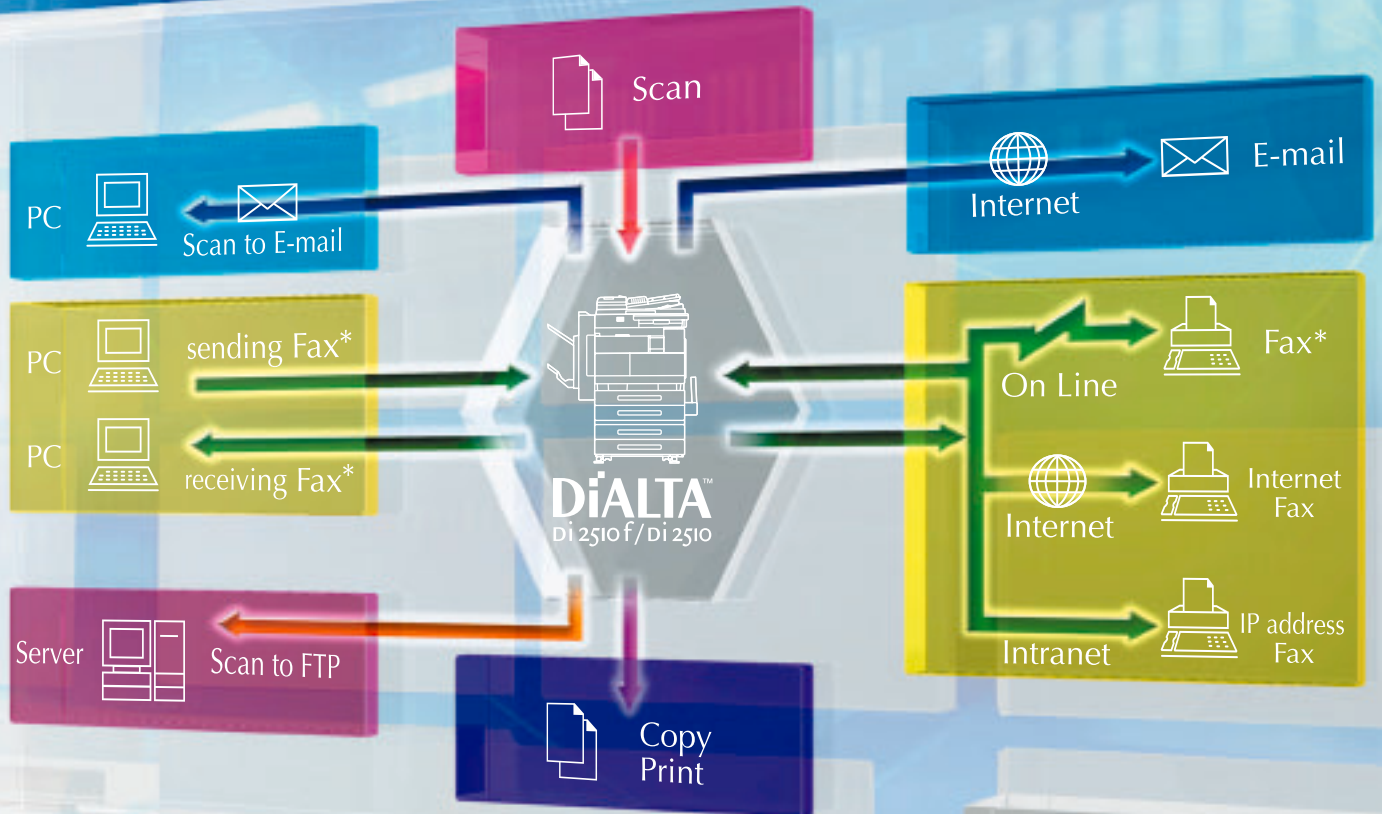

\* The Di2510f exclusively.



An optional Network Interface Card NC-4 is required.

### You get a wide variety of utilisations because data is sent by e-mail

When the optional Network Scan Kit SU-2 or Internet Fax & Network Scan Kit SU-3 are attached.

#### Scanned data can be sent directly by e-mail [Scan to E-mail]

Data scanned by the Di2510f/Di2510 can be sent directly by e-mail to a variety of recipients, whether it is inside or outside the office, or to a mobile PC or your own PC. The one-touch panel allows you to set recipients and subject titles. This makes sending e-mail to multiple recipients not only possible, but also easier. Furthermore, saving and filing used data is simple because now all data is in e-mail form.

#### Now send easy-to-use PDF files [General-Purpose Image Format Support]

Scanned data that you attach to e-mail documents can be sent in easy-to-use formats like TIFF or PDF. Now, received data can be more widely used, and on a variety of different platforms.

#### Send large-volume data easily [E-mail Packet Sending Function]

This function divides large data-filled e-mail before sending them. Thus, related problems are eliminated even if there are e-mail addresses where the data amount is limited to reduce the burden on the network or mail server. Now, there is no need to compress data, or separate it into smaller files to send it in several e-mail messages.

#### Simple One-Touch Panel Operation

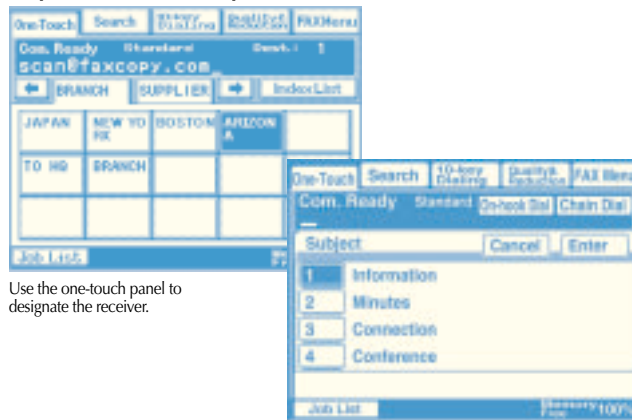

Use the one-touch panel to designate the receiver.

Select subjects using the "Choose Subject" menu.

#### Scan to E-mail

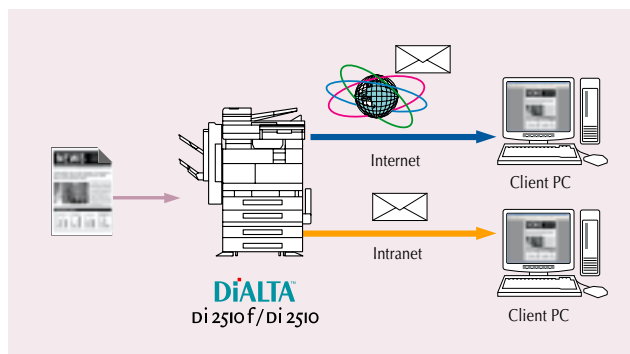

### Sharing data within a work group is more efficient with network scanning functions

When the optional Network Scan Kit SU-2 or Internet Fax & Network Scan Kit SU-3 are attached.

#### Quickly convert paper documents into electronic data [High-Speed Network Scanner]

It high-speed scans at 25 pages/min\* in high-quality 600dpi, and converts paper documents into PDF or TIFF format. This data can then be directly stored onto a PC or a server, And using a simple control panel operations.

\* A4 Crosswise

#### Share documents by way of the main body's HDD [Scan to HDD]

By storing scanned documents or image files onto the large, 40GB hard disk, any client PC on the network can check and download data using their Web browser, or applications that support TWAIN.

Note : When the optional Hard Disk Drive Kit HDD-6 is attached.

#### Send data straight to a directory on the server [Scan to FTP]

This function lets you scan documents, send them to an FTP server, and store them in any directory you specify. Client PCs can then access the server to download the stored documents. This is a highly effective way to share large volumes of data that would be otherwise difficult to send via e-mail.

#### Scan to FTP

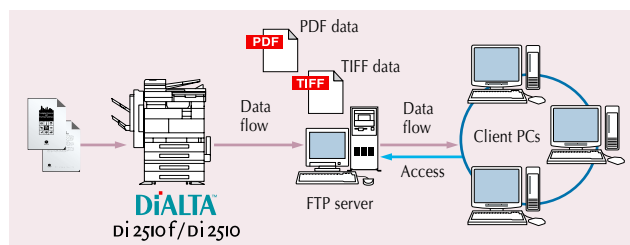

# dramatic changes in workflow. that surpasses the concepts of time and place.

## Bring greater efficiency to your work with our new fax flow

When the optional Internet Fax & Network Scan Kit SU-3 are attached.

### Reduce long distance communication costs [Internet Fax Function]

Di2510f Di2510

Internet use allows you to greatly reduce long-distance transmission fees. In addition, full mode compatibility makes it possible to send pages and images in high-quality 600dpi as well as at sizes of up to A3. A communication report lets you confirm receipt by the destination machine in real-time for extra reliability.

Note1 : An e-mail environment is required.

Note2 : The receiver's side must have a compatible Internet FAX machine.

### Cut fax communication costs using your existing network [IP Address Fax Function]

Di2510f Di2510

Faxes can be exchanged directly by DiALTA unit connected to your Intranet. This means you can send or receive faxes between machines over your existing network for zero costs.

#### Internet Function/IP Address Fax Function

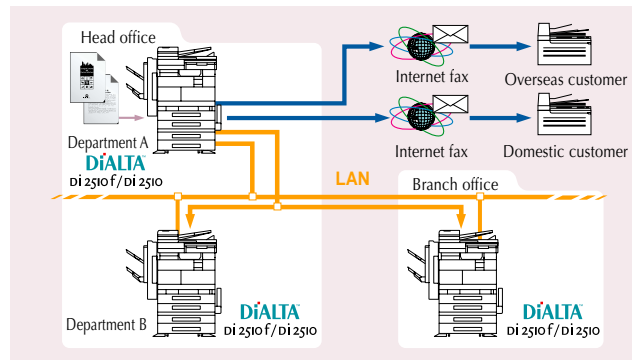

### Send faxes right from your desk [Direct Transmission from a PC]

Di2510f

Send document data directly to an outside fax via the Di2510f right from your PC. Now, there is no need to print the data out before faxing, thus minimising image degradation. You can also send data to a fax and e-mail address simultaneously to increase work efficiency.

### Faxes can be automatically sorted and distributed [Fax Forwarding Function]

Di2510f

You can forward the data from incoming faxes to alternate fax machines\*, or to specific client PCs. This eliminates the work of distributing faxes manually, and speeds up responses by guaranteeing that faxes don't just sit on the machine unnoticed. You can also choose to store the data at designated locations, or forward it to additional users.

\* Internet Fax & Network Scan Kit SU-3 are not necessary.

#### Fax Forwarding Function

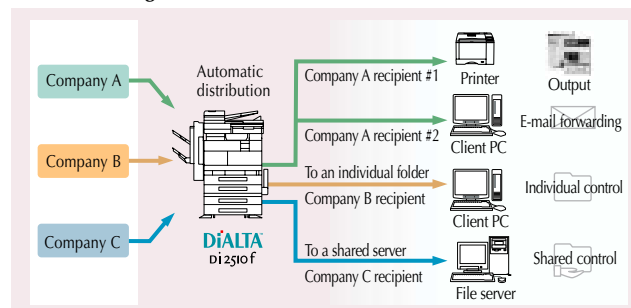

For instance, an order that is faxed to Company A recipient #1 can be simultaneously printed and forwarded to Company A recipient #2 to allow speedier information sharing and faster customer response.

## Faster, more advanced functions can greatly reduce your fax jobs

Di2510f

The following functions can only be used with the Di2510f. It does not require an optional Printer Controller.

### Get high-speed faxing over phone lines [Super G3 Fax Function]

By employing international Super G3 standards and providing high-efficiency JBIG data compression/decompression as a standard function, we have achieved less-than-3-seconds\* high-speed faxing over an ordinary phone line. This lets you send large numbers of documents faster. Photos and other halftone images can also be sent high speed.

\* Calculated when sending an A4 page containing approx. 700 characters at standard image quality. This includes only the time spent for electronic transmission of image data, and does not include paper feed or output times.

### Registering frequently used destinations further speeds up the fax process [One-Touch Dial, Speed Dial]

Register up to 540 frequently used fax numbers. Plus, you can register up to 30 numbers in the One-Touch programming function.

### Your documents are always assured of correct faxing [Rotate Send/Receive Function]

The direction of documents stored in memory is automatically rotated 90° to match the size and direction of the paper in the destination machine. This ensures that you are able to send documents correctly, and without having the image cut off or the size reduced. When receiving faxes, the documents sent from the other machine are adjusted so that they will always be output in the correct direction.

#### 90° Image Rotation

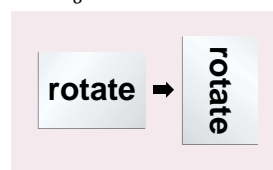

Note : The Rotate Send Function works only when documents are in the A4 Crosswise position. The Rotate Receive Function works only when documents are in A4/B5.

# Create

## Convert documents to electronic data that zips through your results that are innovative and creative.

An optional Network Interface Card NC-4 is required.

Combined with our software, data can be processed and output quickly and easily

Scanned documents are automatically processed into an easy-to-use, easy-to-see format

[PageScope Cabinet\*]



Document files that have been converted to data can be easily transferred with their images automatically corrected according to your needs. With easy-to-see thumbnail image displays and simple drag & drop operations, PageScope Cabinet lets you sort documents into groups, as well as organise and combine them the way you want.

\* Bundled with the optional Network Interface Card NC-4.

### Easy data scanning

Paper documents scanned at high speed by the Di2510f/Di2510 can be automatically forwarded to an FTP receiving folder on specified client PCs. Now, it is not necessary to set an exclusive server.

Note : When the optional Network Scan Kit SU-2 or Internet Fax & Network Scan Kit SU-3 are attached.

### Image-correction scans data for easier reading

No longer is there a need to re-scan paper documents when the image is slanted or off-centred. You can use PageScope Cabinet's image correcting functions to position them for easier reading.

#### Slant correction

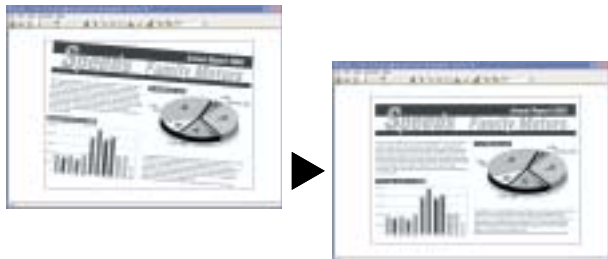

### Easy printing and e-mailing with simple drag & drop operation

Simply drag & drop documents onto the printer or mailer icons to print or attach processed data to an e-mail message. And by adding your most frequently used functions to the launcher area, you can greatly speed-up your output as well as easily open your files.

#### Thumbnail displays

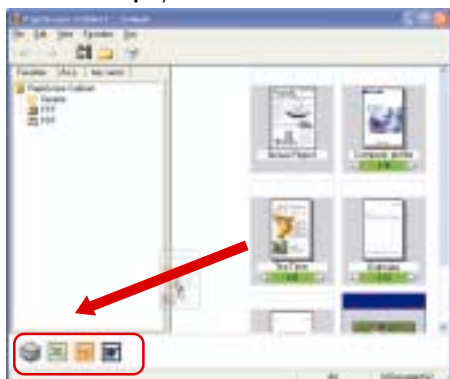

Launcher area

Utilise documents in your PC regardless of their format

[PageScope Work Palette\*]



Konica Minolta's PageScope Work Palette makes it easy to group or rearrange documents in simple page units, even when the documents have been created using different applications. It also lets you extract the necessary parts of existing data to easily create new documents. Combined with the Di2510f/Di2510 finishing functions, it allows you to quickly create attractive documents in-house.

\* Optional (Adobe Acrobat is required to perform these functions).

### Import and Save documents into the widely used PDF format

You can create a PDF file by simple dragging & dropping operation. This is a simple way to store data in a format that is both easy to access and easy to use.

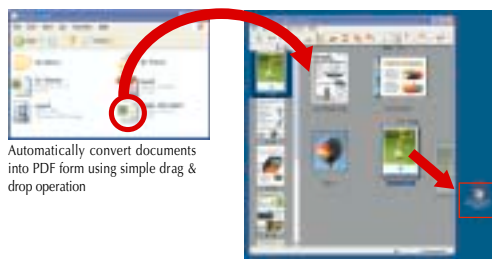

Automatically convert documents into PDF form using simple drag & drop operation

The edited file is saved onto your desktop in PDF form.

### Use thumbnail images to edit documents while confirming their order [Page Editing Function]

The page edit window lets you manage documents in page units, allowing you to group them or rearrange their order. Editing steps such as extracting a page from a document or merging documents can also be performed.

#### Rearrange document sequences

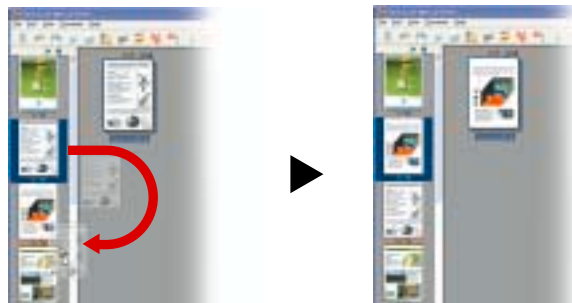

Just drag & drop the second page of this grouped document file.

The second and third pages are rearranged into the correct order.

#### Merge



Combine related documents using a simple drag & drop operation.

#### Divide

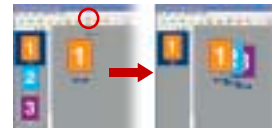

Merged documents can be divided just as easily in a single step.

## Outputtings operations that employ advanced networking functions

### Documents can be printed from any client PC on the network [High-Speed Network Printer]

Combined with the optional Printer Controller, the Di2510f/Di2510 expands into a high-speed network printer. It allows client PCs connected to the network to print pages up to A3 size, and at a speed of 25 pages/min\*1. IPP protocols are supported, and printing can even be done from remote PCs and mobile terminals\*2.

\*1 A4 Crosswise

\*2 Requires an environment that enables access into the internal network.

### Print settings are made in our easy-to-understand window [GUI Print Settings]

The Di2510f/Di2510's handy window with descriptive graphics enables worry-free print settings, such as paper sizing, stapling, and additional finishing functions.

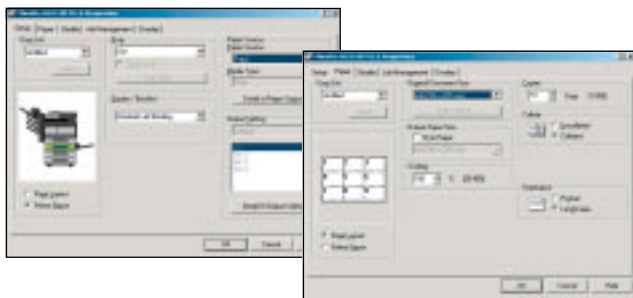

### Utilise the copier's various finishing functions even when printing [Finishing Functions]

Two-sided copying/printing, stapling, hole punching, saddle stitching, as well as additional finishing functions can be used both when copying and when printing from a PC.

Note : When an optional Finisher is attached.

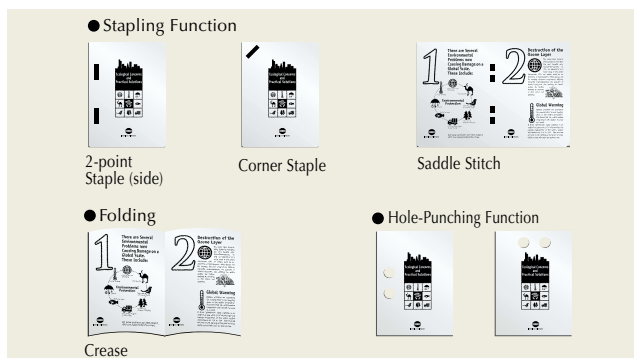

### Protect important documents in today's open network environment [Lock Job Function]

Apply a security lock on the output of all confidential data. Now, outputting locked data is impossible without entering a password into the control panel. This function helps eliminate sensitive data from being seen or used by those without authorisation.

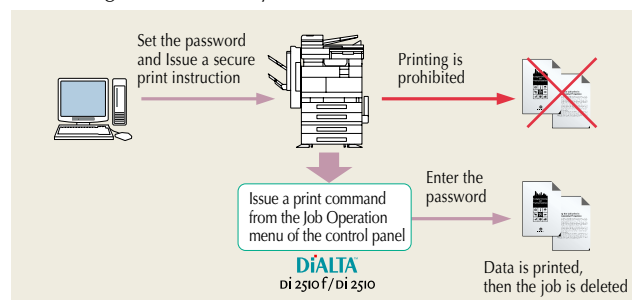

### Make detailed device settings from a client PC [PageScope Light]

PageScope Light lets you handle the detailed settings and status confirmation from your Web browser. Easily make detailed device settings such as one-touch fax numbers and scanned data destinations\*, right over the network. There is no need to install any special software because now, the operation is done entirely with your Web browser.

\* When the optional Network Scan Kit SU-2 or Internet Fax & Network Scan Kit SU-3 are attached.



## PAGESCOPE SUITE Concept

PageScope Suite is Konica Minolta's unique software group, which together with Konica Minolta's output devices provide the most efficient business solutions that best fit today's various network environments. This software group, which consists of 3 categories, will accurately solve the numerous problems that occur daily in the office. By fusing hardware and software, it will provide a rapid increase in business productivity.

# Activate

Enjoy a host of advanced and versatile copying functions.

An array of impressive functions in a compact body that boasts office productivity

## Reactivation when you need it most

### [Short Warm-up Time] [First Copy Speed]

The Di2510f/Di2510 switches on to full operating condition in 17 seconds or less\*, and achieves a fast First Copy Speed of 5.3 seconds or less. These reductions in waiting time help get you back to work faster.

\* Di2510f: 22 seconds or less

## Two-sided copying not only saves paper, but also allows easy booklet creation

### [Standard Duplexing]

The Duplexing function that enables fast two-sided copying in 100% productivity is provided as a standard function. This not only saves paper, but also makes it easy to create attractive booklets.

## Sort multiple outputs, even without a sorter

### [Electronic Sort Function]

The Electronic Sort function can handle multiple output sorting jobs without a sorter. This eliminates the time consuming work of sorting documents by hand. Now, you can sort, copy or print outputs even without having to add-on an option.

\*1 When the Finisher FN-117 is mounted.

\*2 When the finisher FN-117 is not mounted with A4, B5 or A5 sheets are set lengthwise and in crosswise directions.

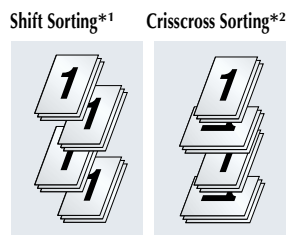

## A compact body and built-in finisher save space

### [Compact Design]

Our finisher is completely built-in, which means the units don't require any space on their sides like conventional finishers do. Combined with their compact design, you get a truly space-saving machine.

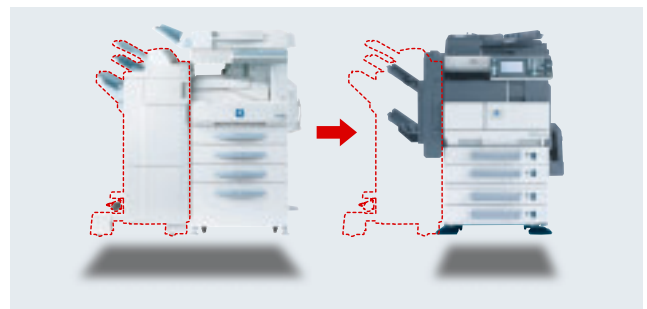

## Our lamp reveals operating status and paper output

### [Status Lamp]

The lamp on the Duplexing Document Feeder indicates the copier's operating status. It lights in green when printing, and in red when an error occurs. It also lights when the paper is



discharged to the output tray, to quickly notify you that a fax has been received or a printing job is finished, so important documents don't go unnoticed.

Compatible to a variety of paper sizes

## Exchangeable paper trays handle a wide range of paper sizes

### [Universal Trays]

Up to four paper-feed trays can be set. Each is a universal tray that holds paper sizes from A5 to A3. Plus, adjusting the tray to handle your required paper size is a snap.

## A large paper supply of up to 150 sheets accepts a variety of media

### [Multiple Bypass Tray]

The 150-sheet Multiple Bypass Tray accepts a variety of media including thick paper, transparencies, labels and envelopes. The easy-to-set-tray makes changing the paper size as well as makes it possible to handle a wide range of paper types.



## Various sized documents can be copied automatically

### [Mixed Original Mode]

Even when you copy different-sized originals, their sizes are automatically detected and copied onto the correct-sized sheets.

#### Auto Paper

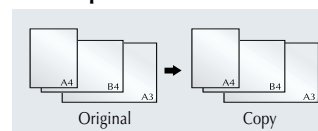

#### Auto Size

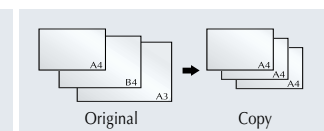

Note : 90° Image Rotation is unavailable in this mode.

## No more worrying about running out of paper while printing

### [Auto Tray Change Function]

If the paper in the tray suddenly runs out before a print job is completed, this function will automatically switch to a different tray that is loaded with the same sized paper. This enables non-stop output, which reduces the downtime required to replenish the paper supply.

## Innovative functions that increase office work efficiency

### Now, save time performing multiple jobs simultaneously [Multi-Access Function]

The Di2510f/Di2510 can accept multiple jobs concurrently. For instance, the units can scan documents\* while outputting, or they can receive print spool data from a client PC, even as they continue to scan large volume documents. This greatly shortens waiting time, and makes office work more efficient.

Note : When the optional Printer controller and Network Interface Card NC-4 are attached.  
\* Network Scan Kit SU-2 or Internet Fax & Network Scan Kit SU-3, are attached.

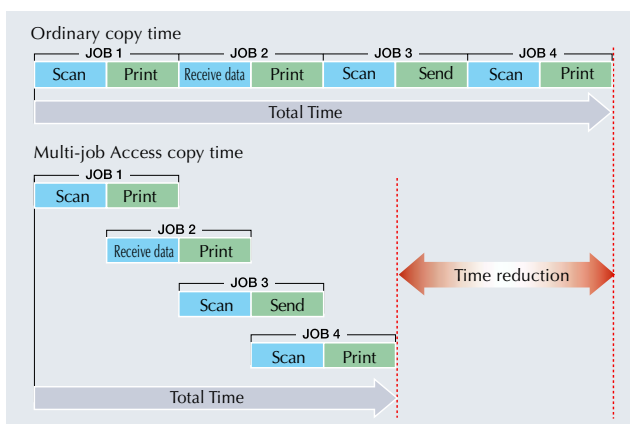

### Complete finishing functions for eye-catching documents [Finishing Functions]

With a finisher mounted, the Di2510f/Di2510 can handle stapling, hole punching, folding, saddle stitching and additional tasks for complete booklet production. This lets you create highly attractive proposals, direct-mail pieces, as well as other materials.

#### Booklet Creation

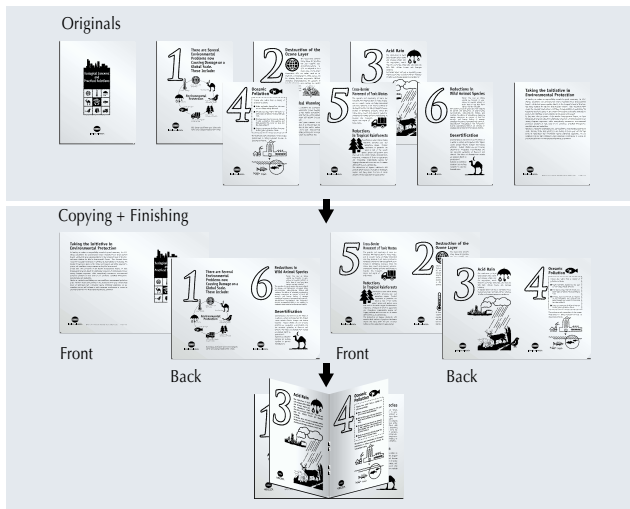

	FN-117	FN-117+PK-6	FN-117+PK-6+SK-1
Coner staple	Yes	Yes	Yes
2 point staple	Yes	Yes	Yes
Hole punching function	No	Yes	Yes
Saddle Stitch	No	No	Yes
Crease	No	No	Yes

### Check settings plus make additional outputs with ease [Memory Recall]

This function allows an initial set of copies to be output separately as a sample. It enables you to check for function setting errors prior to outputting a number of jobs.

#### Memory Recall Output Order

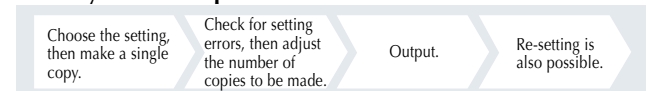

### Copy the contents of 2 to 4 pages onto a single page [2 in 1/4 in 1 Copy]

You can copy two or four documents onto a single page. Combining this function with duplex copying, you can copy up to eight pages onto one copy page. This lets you effectively save on paper costs, as well as keep tcopy speed during duplex copying the same fast 25 pages/min\* as that of one-sided copying.

\* A4 Crosswise

#### 2 in 1 Copy

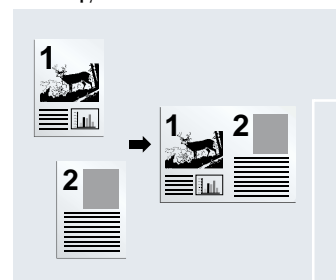

#### 4 in 1 Copy

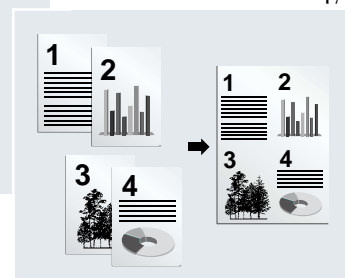

### Print consecutive numbers or category stamps during output [Water Mark/Distribution Number]

By utilising water marks such as "Confidential," or setting marks on consecutive pagenumbers, you can automate the manual stamping that was previously required when preparing important meeting materials. Combining this with the finishing functions eliminates the need for tedious manual work when producing a number of documents.

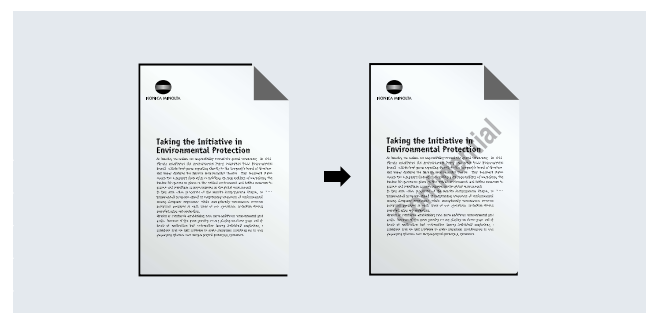

# Operate

Next-generation specs and design create a link between

## Universal design for operator comfort

You demand business efficiency. So it is both vitally important and common sense to eliminate the stress associated with machine operation. At the same time, superior styling is also a requirement. Konica Minolta's goal and result – **"Comfortable use that appeals to everyone"**

**Matches the office, matches the operator and adjusts to an easy-to-use angle**  
**[Tilt Control Panel]**

The angle of the control panel can be adjusted to three levels, 7°, 26° and 43°, to the working position that best suits the operator. This enables the user to assume a natural posture, and assures stress-free operation.

**We paid extra attention to the details to increase your ease of use**  
**[Control Panel with Universal Design]**

In addition to the copy and fax essentials, we concentrated on controls such as display switching and power ON/OFF\*, conveniently placing them on the front of the control panel. Further, from a universal design standpoint, we carefully considered the size and layout of the buttons, as well as the screen displays for your enhanced ease of use.

\* The main power switch is located on the side of the machine.

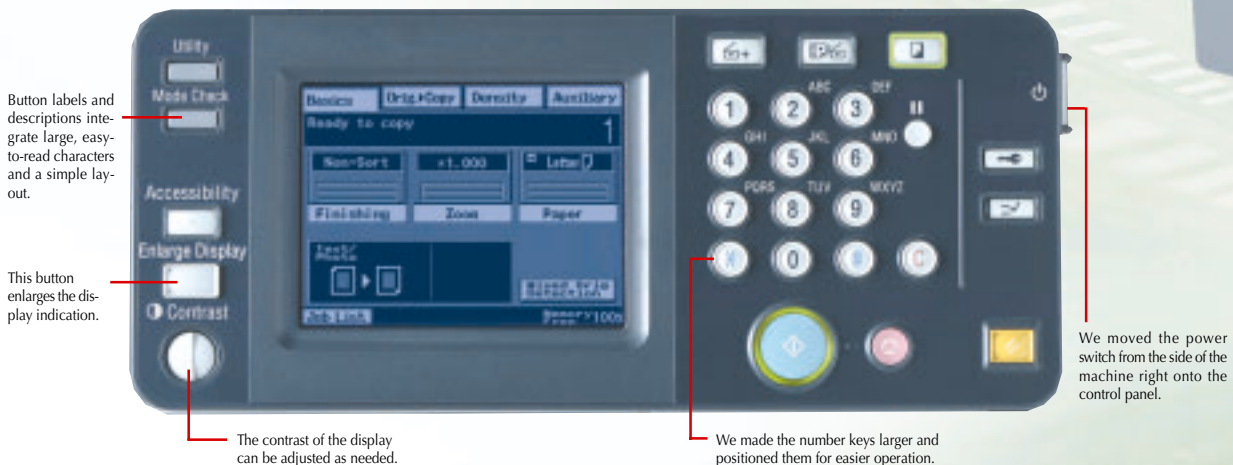

**New user friendly body colour**  
**[Two-tone Colours]**

We've used darker colours on the top-half of the machine to boost its visibility and recognition. This new styling combines the practicality of making the paper and operating buttons easier to identify, with Konica Minolta's modern approach to product design.

## you and your machine.

### A number of easy-to-operate features have been added to the Duplexing document feeder [Document Feeder Design]

A handle and easy-to-read scale have been added to the document feed tray, which is actively used in copying and scanning. The additions of these design-based features are what make the Di2510f/Di2510 even easier to use.

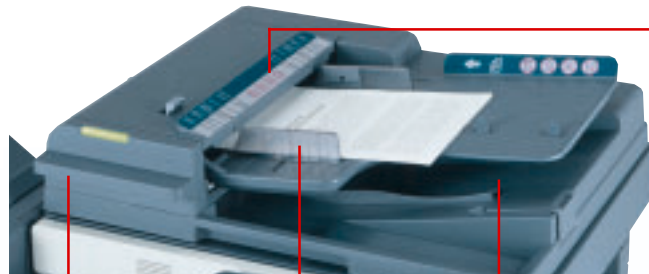

This high-contrast scale makes it easy to check the size of an original.

The added handle improves the grip.

By using a transparent material for the original guide, the guide setting can be viewed from a wider direction than ever before.

By texturing the document handling tray and discharge area, we made it easier to grasp pages.

### A paper path that's easy to locate [Concentrated Paper Path]

Paper feed parts that see the most frequent operation have been concentrated in the right side of the machine. This simplifies the paper path, and enables problems to be resolved quickly in the event of a paper jam.



### Now, easy one-touch toner bottle replacement [Toner Front Access Design]

The front access design makes it easy to replace the toner bottle. And the entire bottle holder pulls out for easy bottle replacement. Now, no more worrying about soiling the surrounding area with toner.



### The easy-handle grip simplifies paper supplying [New Grip Design]

A new grip has been included for easier handling from either the top or bottom direction. This feature makes the paper feed tray simple to pull out, for smoother paper supplying.



## Di2510 Specifications

### General

Type: Digital Copier/Printer/Scanner  
 Process: Laser Electrostatic  
 Gradation: 256 gradations  
 Memory: 64MB (Max.192MB)  
 Warm-Up Time: Di2510: 17 seconds or less  
 Di2510f: 22 seconds or less  
 Power Consumption: 1.5kW or less  
 Dimensions: 677 (W) x 710 (D) x 718 (H) mm  
 (26-3/4" x 28" x 28-1/4")  
 Weight: 74kg (136 lb.)

### Paper Handling

Type of Originals: Sheets, Book, 3-D Objects  
 Original Size: Max.: A3 (Ledger)  
 Paper Capacity: Standard: 1,150sheets (500 x 2+150)  
 Max.: 3,650sheets (500 x 2+2,500+150)  
 Output Size: A6 to A3 (3-1/2" x 5-1/2" to 11-3/4" x 17")  
 Materials: Plain Paper (56-90g/m<sup>2</sup>)  
 Thick Paper (91-210g/m<sup>2</sup>)  
 OHP Sheet\*  
 \* Multiple Bypass

### Copy

Copy Speed: 25 pages/min\*  
 1st Copy: 5.3 seconds or less\*  
 Resolution: 600dpi x 600dpi  
 Magnification: x 0.250-4.000 (Preset or Variable)  
 Exposure Modes: Text/Photo Mode,  
 Photo Mode,  
 Text Mode  
 Multiple Copy: 1-999, Count-Down,  
 Interrupting Capability  
 \* A4 Crosswise

## Printer Controller Pi3505e, Pi3505e/PS Specifications

### General

CPU: RM5231A (PMC Sierra)  
 includes copier controller  
 Memory: Pi3505e: Standard: 32MB (Max.224MB)  
 Pi3505e/PS: Standard: 128MB (Max.320MB)  
 Operating System: Pi3505e: Standard: Windows98, Me  
 WindowsNT4.0/2000/XP  
 Pi3505e/PS: Standard: Windows98, Me  
 WindowsNT4.0/2000/XP  
 MacOS System8.6 or Later  
 Interface: Ethernet (10BASE-T, 100BASE-TX),  
 (Optional) USB1.1  
 Parallel Interface  
 Software: PageScope Light (Embedded),  
 PageScope Net Care,  
 PageScope Network Setup,  
 PageScope EMS Plug-Ins,  
 PageScope NDPS Gateway,  
 PageScope Cabinet

### Print

Speed: 25 pages/min\*  
 Resolution: 600dpi x 600dpi  
 Network Protocols: Pi3505e: TCP/IP, IPX/SPX  
 Pi3505e/PS: TCP/IP, IPX/SPX, AppleTalk  
 Printer Languages: Pi3505e: PCL 5e, PCL 6  
 Pi3505e/PS: PCL 5e, PCL 6, PostScript 3 Emulation  
 Fonts: Pi3505e: PCL Fonts (46 fonts)  
 Pi3505e/PS: PCL Fonts (46 fonts)  
 PostScript Font (136 fonts)  
 \* A4 Crosswise

### Scanning Function Specification

Speed: 25 pages/min\*  
 Resolution: 200dpi x 100dpi, 200dpi x 200dpi,  
 400dpi x 400dpi, 600dpi x 600dpi  
 Protocols: TCP/IP, SMTP, FTP  
 E-mail Format: MIME  
 Date Format: TIFF, PDF  
 \* A4 Crosswise

### Internet Fax Specification

Internet Protocols: TCP/IP, SMTP, POP3  
 Transmission mode: Simple Mode, Full Mode  
 E-mail Format: MIME  
 Date Format: TIFF-F  
 Date Compression Mode: MH, MR, MMR  
 Document Size: A4, B4, A3 (If receiving fax machine has capability)  
 Scan Resolution: 200dpi x 100dpi, 200dpi x 200dpi,  
 400dpi x 400dpi, 600dpi x 600dpi  
 (If receiving fax machine has capability)

### Options

Network Interface Card (NC-4),  
 Parallel Interface Kit,  
 Hard Disk Drive Kit HDD-6 (40GB)  
 32MB Memory (M32-4),  
 64MB Memory (M64-2),  
 128MB Memory (M128-3)

## Di2510f Facsimile Specifications

Communication Line: PSTN, PBX  
 Modem Speed: 33,600/31,200/28,800/26,400/24,000/  
 21,600/19,200/16,800/14,400/12,000/9,600/  
 7,200/4,800/2,400 bps (Automatic fallback)  
 Transmission Speed: Less than 3 seconds\*  
 Scanning Resolution: Standard: 203 x 98dpi,  
 Fine: 203 x 194dpi,  
 Super Fine: 406 x 391dpi  
 Max. Document Size: A3  
 \* A4 Crosswise

### Recording Size:

A5 Crosswise/ B5 Crosswise/ A4/  
 B4 lengthwise/ A3 lengthwise  
 G3, Super G3

### Compatibility:

Data Compression Method:

Transmitting Functions:

MH/ MR/ MMR/ JBIG  
 Timer Transmission,  
 Confidential Mailbox Transmission,  
 Polling Transmission, Broadcast,  
 Relay Broadcast, One-Touch Dialling,  
 Speed Dialling, Group Dialling,  
 Memory Transmission

### Receiving Function:

Memory Reception,  
 Polling Reception,  
 Selective Polling Reception,  
 Confidential Mailbox Reception

### Options

TX Marker STAMP UNIT 2  
 Spare TX Marker STAMP 2

## System Options

- Printer Controller Pi3505e
- Printer Controller Pi3505e/PS
- Hard Disk Drive Kit HDD-6
- Staples MS-2C  
Mounts to the SK-1 for stapling.
- Saddle Kit SK-1  
Mounts to the FN-117 perform centre stapling and folding.
- Punch Kit PK-6  
Mounts to the FN-117 for hole punching.
- Additional Bin Kit AK-1  
Allows you to add up to 200 sheets bins.
- Staples MS-5D

- Expansion Memory  
M32-4 (32MB)  
M64-2 (64MB)  
M128-3 (128MB)

- Network Scan Kit SU-2
- Internet Fax & Network Scan Kit SU-3

- Mail Bin Kit MK-1  
Mounts to the FN-117 to let you designate specific bins for printer output, as well as to set bins for special purposes.

- Built in Finisher FN-117  
The FN-117 can staple up to 50 copies per set.

\*The Mail Bin Kit MK-1 and Saddle Kit SK-1 cannot be attached simultaneously.



- Duplexing Document Feeder AFR-19  
Accepts up to 80 sheets for two-sided copying.



- Original Cover Kit OC-6



- Job Separator JS-203  
Lets you separate and designate the location for copy and print output.  
\*The Built in Finisher FN-117 and Job Separator JS-203 cannot be attached simultaneously.



- 2Way Paper Feed Cabinet PF-210  
Holds from A5 to A3 paper. Provides storage capacity for up to 1,000 sheets.



- Paper Feed Cabinet PF-124  
Holds from A5 to A3 paper. Provides storage capacity for up to 500 sheets.



- Large Capacity Cabinet PF-122  
Holds up to 2,500 sheets of A4 or B5 paper.

- Copy Desk CD-4M

Product appearance, configuration and/or specifications are subject to change without notice.

DiALTA and PageScope are registered trademarks or trademarks of KONICA MINOLTA BUSINESS TECHNOLOGIES, INC. Windows is a registered trademark or trademark of Microsoft Corporation. Adobe and PostScript are registered trademarks or trademarks of Adobe Systems Incorporated. All other brand and product names are registered trademarks or trademarks of their respective owners.

\* As an ENERGY STAR Partner, KONICA MINOLTA BUSINESS TECHNOLOGIES, INC. has determined that this product meets the ENERGY STAR guidelines for energy efficiency.

\* ENERGY STAR is a U.S. registered mark.

Konica Minolta copiers and multi-functional peripherals are designed with the environment in mind.



- Meets ENERGY STAR Guidelines
- The Use of Recycled Materials
- Toner Recycle Mechanism
- Production at ISO-Certified Factories

Konica Minolta genuine consumables and parts

To ensure the best possible performance from our copiers in terms of cost, copy quality, and service life, Konica Minolta extends its technical expertise as a manufacturer of precision equipment—to the development and production of high-quality consumables and parts. For optimum productivity, we recommend the use of genuine Konica Minolta consumables and parts.

Konica Minolta CS Digital Technologies are incorporated into the DiALTA Di2510f/Di2510

Image quality, Productivity, Operability, Reliability, Connectivity and the Environment. We've reexamined these six features, essential in all business equipment, to create Konica Minolta's unique image information products. The DiALTA Di2510f/Di2510 using these innovative CS Digital Technologies, provides efficient document work for complete customer satisfaction.



**KONICA MINOLTA  
 BUSINESS TECHNOLOGIES, INC.**  
 1-6-1 Marunouchi Chiyoda-ku, Tokyo, Japan  
<http://www.biz.konicaminolta.com>

This catalogue was printed using recycled paper and soy ink.

9251-3126-21 0409(E)-C1 Printed in Japan